

# HOUSEWATCH<sup>®</sup>

## 10W & 20W SPOTLIGHT

# I N S T R U C T I O N S

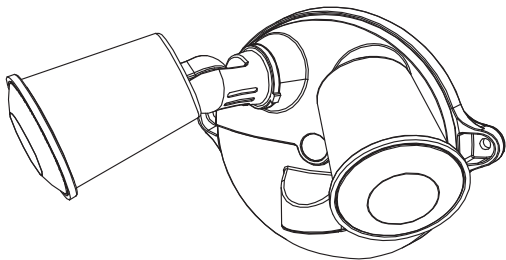
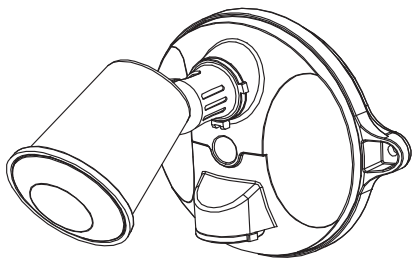

**10W Model No's: 55-138 & 55-139**

**20W Model No's: 55-226 & 55-227**



## CONTENTS

INTRODUCTION .....	3
IMPORTANT SAFETY INSTRUCTIONS .....	3
INSTALLING THE SPOTLIGHT .....	4-7
MAINTENANCE PROGRAM .....	7
TROUBLESHOOTING.....	8
SPECIFICATIONS.....	8
WARRANTY INFORMATION .....	10

## INTRODUCTION

The Housewatch LED spotlight is a low-energy, high powered outdoor fitting. The LED spotlight is suitable for installation on walls in a range of outdoor locations including entrances, gardens, staircases, garages and parking areas.

## IMPORTANT SAFETY INSTRUCTIONS

Please follow these instructions carefully before attempting to install and operate this spotlight.

- ⚠ Ensure the voltage marked on the product is the same as the electrical power supply to be used.
- ⚠ DO NOT direct the light into a person's eyes. This spotlight has a very intensive light output, which if incorrectly used could cause eye damage.
- ⚠ WARNING: Risk of fire. Do not aim the fitting at a combustible surface within 1m.
- ⚠ Must be installed by a licensed electrician in accordance with AS3000:2007.

# INSTALLING THE SPOTLIGHT

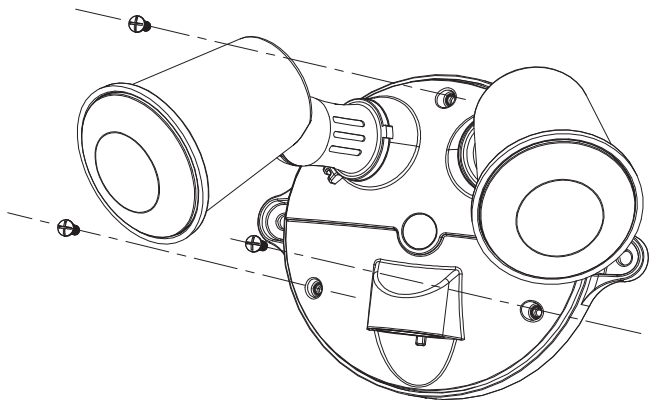

## 1. REMOVE FRONT COVER

Use a Phillips head screwdriver to unscrew the three screws on the front cover, then open the back junction box.

# INSTALLING THE SPOTLIGHT

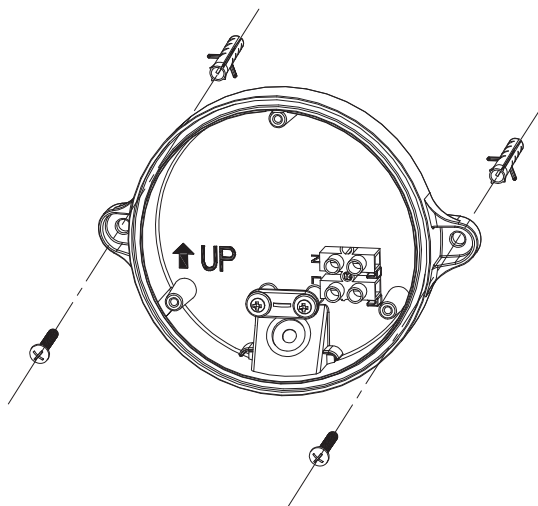

## 2. FIX THE SPOTLIGHT JUNCTION BOX TO THE WALL

Using the screws and screw plugs provided, secure the spotlight horizontally to the wall.

# INSTALLING THE SPOTLIGHT

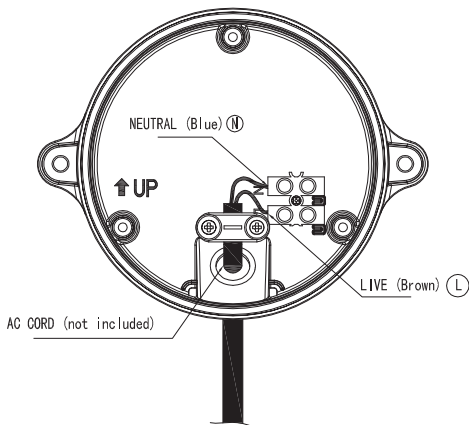

## 3. CONNECTION

Connect the cable to the terminal block on the wall plate as above.

NEUTRAL	(Blue)	<b>N</b>
LIVE	(Brown)	<b>L</b>

## 4. REPLACE FRONT COVER

Rescrew the front cover in place with a Phillips head screwdriver.

# INSTALLING THE SPOTLIGHT

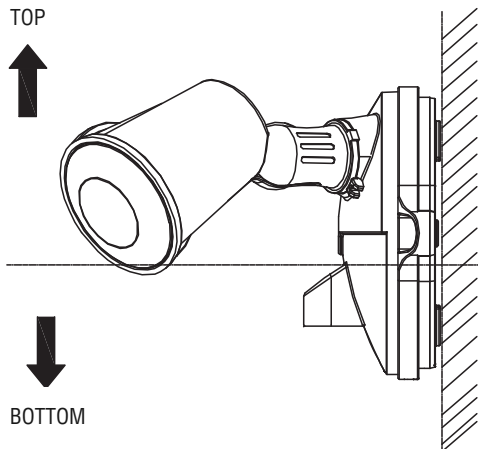

## OUTDOOR WALL INSTALLATION REQUIREMENT

### MAINTENANCE PROGRAM

1. After a period of time the lamp and lantern surfaces can accumulate dust and debris. This accumulation of dust and debris can directly influence the performance of lamps and fitting. A regular cleaning maintenance program for lamps and lanterns should be run on a 6 monthly cycle.
2. During the regular cleaning maintenance program it is important to check that all parts are in good condition and any loose screws are tightened.
3. During the cleaning process it is important to not use corrosive or volatile liquids. The use of corrosive or volatile liquids may cause a chemical reaction and may influence the performance. It is recommended to use a damp cleaning cloth.

# TROUBLESHOOTING

Problem	Recommended Action
Lights do not turn on	1) Check light switch is on 2) Check wiring

# SPECIFICATIONS

Model Description:	10W Light	20W Light
	55-138 55-139	55-226 55-227
Detection Angle:	140°	
Power Supply:	AC 100-240V (50Hz)	
Max. Switchable Load:	LED 10W	LED 2 x 10W
Lamp Type:	10W high power LED	
Environmental Protection:	IP54 (suitable for outdoor use)	

\*Specifications are subject to change without prior notice.







## MANUFACTURER'S WARRANTY

This Housewatch product is guaranteed for a period of 2 (Two) years from date of purchase, provided the product has been installed in accordance with this instruction manual and local electrical wiring regulations and codes of practice.

This guarantee shall become invalid if this product has been incorrectly installed, misused, tampered with or accidentally damaged.

If the goods are defective, we undertake to repair or replace the goods or any part of them that is defective; or provide again or rectify any services or part of them that are defective; or wholly or partly recompense you if they are defective.

This guarantee is in addition to other rights and remedies available to consumers, all of which are given by us to you if you are a consumer. Our Goods come with guarantees that cannot be excluded under the Australian Consumer Law. You are entitled to a replacement or refund for a major failure and for compensation for any other reasonably foreseeable loss or damage.

You are also entitled to have the goods repaired or replaced if the goods fail to be of acceptable quality and the failure does not amount to a major failure. If you wish to make a warranty claim, please return this product to the original place of purchase together with your purchase receipt, or contact us using the below details.

Proudly Distributed by



**Repelec (Aust)**

**Locked Bag 45**

**Plumpton NSW 2761**

**Ph: 1300 555 586 Fax: 1300 666 066**

**Email: [info@housewatch.com.au](mailto:info@housewatch.com.au)**