

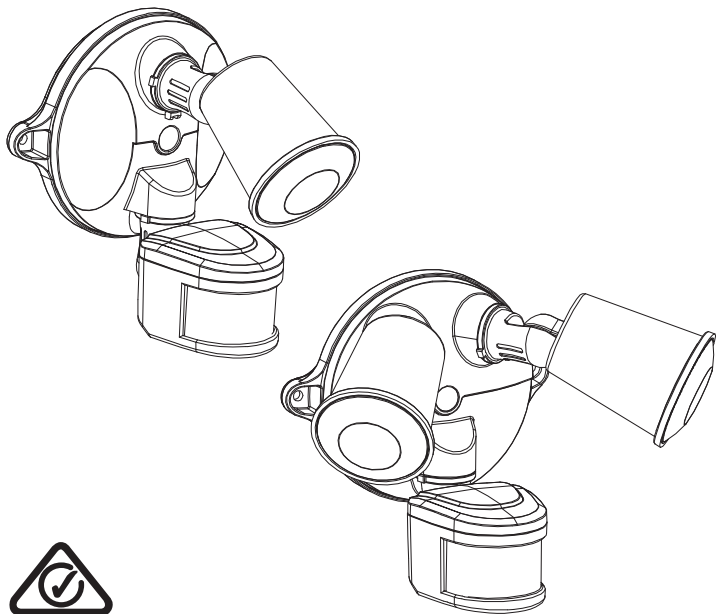

10W & 20W SENSOR SPOTLIGHT

I N S T R U C T I O N S



10W Model No's: 55-136 & 55-137

20W Model No's: 55-224 & 55-225



CONTENTS

INTRODUCTION	3
IMPORTANT SAFETY INSTRUCTIONS	3
INSTALLING THE SPOTLIGHT	4-7
OPERATION AND TESTING	8-10
SETTING UP FOR AUTOMATIC OPERATION.....	11
MAINTENANCE PROGRAM	12
TROUBLESHOOTING.....	13
SPECIFICATIONS.....	14
WARRANTY INFORMATION	16

INTRODUCTION

The Housewatch LED spotlight is a low-energy, high powered outdoor fitting. The LED spotlight is suitable for installation on walls in a range of outdoor locations including entrances, gardens, staircases, garages and parking areas.

IMPORTANT SAFETY INSTRUCTIONS

Please follow these instructions carefully before attempting to install and operate this spotlight.

- ⚠ Ensure the voltage marked on the product is the same as the electrical power supply to be used.
- ⚠ DO NOT direct the light into a person's eyes. This spotlight has a very intensive light output, which if incorrectly used could cause eye damage.
- ⚠ WARNING: Risk of fire. Do not aim the fitting at a combustible surface within 1m.
- ⚠ CAUTION: Keep the sensor at least 51mm away from the lamps.
- ⚠ Must be installed by a licensed electrician in accordance with AS3000:2007.

INSTALLING THE SPOTLIGHT

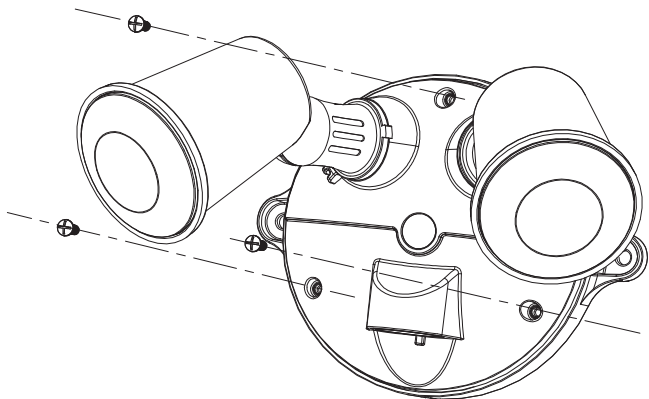

1. REMOVE FRONT COVER

Use a Phillips head screwdriver to unscrew the three screws on the front cover, then open the back junction box.

INSTALLING THE SPOTLIGHT

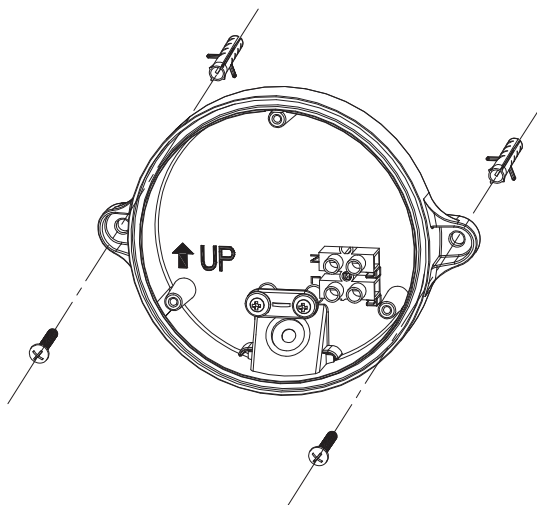

2. FIX THE SPOTLIGHT JUNCTION BOX TO THE WALL

Using the screws and screw plugs provided, secure the spotlight horizontally to the wall.

INSTALLING THE SPOTLIGHT

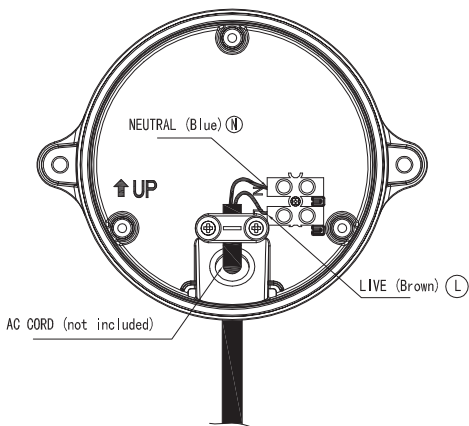

3. CONNECTION

Connect the cable to the terminal block on the wall plate as above.

NEUTRAL (Blue) N

LIVE (Brown) L

4. REPLACE FRONT COVER

Rescrew the front cover in place with a Phillips head screwdriver.

INSTALLING THE SPOTLIGHT

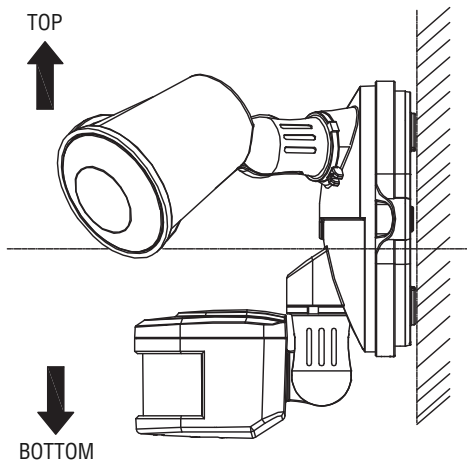

OUTDOOR WALL INSTALLATION REQUIREMENT

OPERATION AND TESTING

WALK TESTING PROCEDURE

The sensor will rotate from left to right and up to down. Adjust the sensor to point in the desired direction for the sensor patterns (see **Figure 1**).

1. Set the two adjustment controls on the bottom of the sensor (see **Figure 2**) to the following positions:

TIME - Fully counter-clockwise

LUX - Fully clockwise

The unit will now operate during daytime as well as night, illuminating the lamp for approximately 5 seconds each time. This allows testing to be carried out to establish the best position for the sensor.

2. Switch on the mains power. The lamp will immediately illuminate as the unit goes through its “warm-up” period. After approximately 1 - 2 minutes the lamp will extinguish. Try to remain outside the detection area during the warm-up period.
3. Walk across the detection area approximately 5 metres from the unit. As you cross a detection “zone” the lamp will illuminate. Now stand still until the lamp extinguishes (this should take approximately 5 seconds).
4. Start moving again. As you cross each “zone” the lamp will illuminate.
5. Repeat the above, walking at various distances and angles to the unit. This will help you to establish the detection pattern.

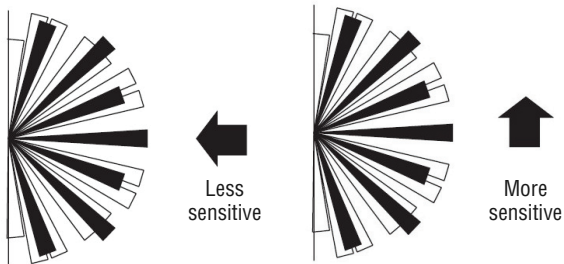
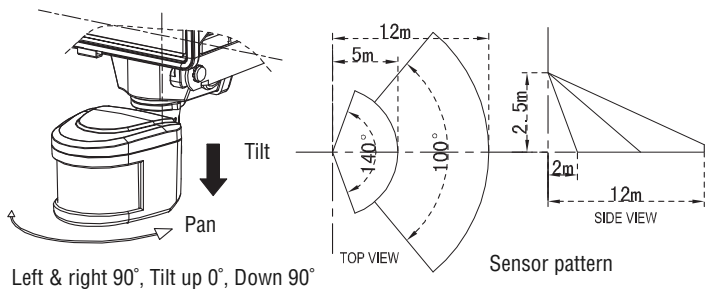

FIGURE 1

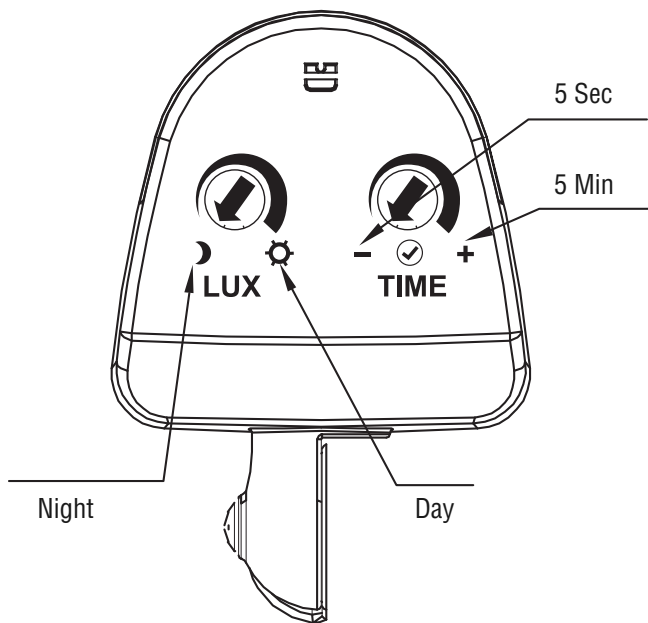

FIGURE 2

SETTING UP FOR AUTOMATIC OPERATION

Once walk tests are complete, the unit can be switched to automatic operation.

The TIME setting controls how long the unit remains illuminated following activation and after all motion ceases. The minimum time (fully counter-clockwise) is approx. 5 seconds, whilst the maximum time (fully clockwise) is approximately 5 minutes. Set the control to the desired setting between these limits.

The LUX control determines the level of darkness required for the unit to start operating. The setting is best achieved by the procedure below:

1. Set the LUX control knob fully counter-clockwise. The unit will now start operating at dusk.

If you require the light to activate earlier, wait until the ambient light level reaches the level of darkness at which you wish the lamp to become operative. SLOWLY rotate the control in a clockwise direction until a point is reached where the lamp illuminates. Leave the control set at this point.

MANUAL OVERRIDE MODE

1. To switch into manual override the power must be switched on/off/on.
2. To reset it back to auto mode, turn off the power and wait 20 seconds before switching the power back on. The unit will go through its warm up cycle before resuming normal operation.

MAINTENANCE PROGRAM

1. After a period of time lamp and lantern surfaces can accumulate dust and debris. This accumulation of dust and debris can directly influence the performance of lamps and lanterns. A regular cleaning maintenance program for lamps and lanterns should be run on a 6 monthly cycle.
2. During the regular cleaning maintenance program it is important to check that all parts are in good condition and any loose screws are tightened. Any damaged parts including screws should be replaced during the regular 6 monthly maintenance program.
3. During the cleaning process it is important to not use corrosive or volatile liquids. The use of corrosive or volatile liquids may cause a chemical reaction and may influence the performance. It is recommended to use a damp cleaning cloth.

TROUBLESHOOTING

Problem	Recommended Action
Lights do not turn on	<ol style="list-style-type: none">1) Check light switch is on2) Check wiring3) Check sensor is level and pointed at the area you desire, and movement is not directly towards the sensor but across the lens. Check sensor is mounted at the recommended height.
Lights flickering on/off	<ol style="list-style-type: none">1) Check position of time adjustment at bottom of sensor. Setting the arrow at "-" gives 5 seconds and setting arrow fully at "+" gives 5 minutes. Adjust to desired time.
Lights do not turn off	<ol style="list-style-type: none">1) Turn time adjustment closer to "-" negative sign at the bottom2) Turn light switch off and then back on after 20 seconds, you are now in sensor mode3) Make sure the sensor is not aimed at something that would cause a temperature change or towards objects which may move.
Sensor coming on during daytime	<ol style="list-style-type: none">1) Turn LUX adjustment at the bottom of the sensor to moon setting

SPECIFICATIONS

Model Description:	10W Sensor Light	20W Sensor Light
	55-136 55-137	55-224 55-225
Detection Range:	Up to 12 metres	
Detection Angle:	140°	
Power Supply:	AC 100-240V (50Hz)	
Max. Switchable Load:	LED 10W	LED 2 x 10W
Lamp Type:	10W high power LED	
Time On Adjustment:	Day or night or night only operation	
Environmental Protection:	IP54 (suitable for outdoor use)	

*Specifications are subject to change without prior notice.



MANUFACTURER'S WARRANTY

This Housewatch product is guaranteed for a period of 2 (Two) years from date of purchase, provided the product has been installed in accordance with this instruction manual and local electrical wiring regulations and codes of practice.

This guarantee shall become invalid if this product has been incorrectly installed, misused, tampered with or accidentally damaged.

If the goods are defective, we undertake to repair or replace the goods or any part of them that is defective; or provide again or rectify any services or part of them that are defective; or wholly or partly recompense you if they are defective.

This guarantee is in addition to other rights and remedies available to consumers, all of which are given by us to you if you are a consumer. Our Goods come with guarantees that cannot be excluded under the Australian Consumer Law. You are entitled to a replacement or refund for a major failure and for compensation for any other reasonably foreseeable loss or damage.

You are also entitled to have the goods repaired or replaced if the goods fail to be of acceptable quality and the failure does not amount to a major failure. If you wish to make a warranty claim, please return this product to the original place of purchase together with your purchase receipt, or contact us using the below details.

Proudly Distributed by



Repelec (Aust)

Locked Bag 45

Plumpton NSW 2761

Ph: 1300 555 586 Fax: 1300 666 066

Email: info@housewatch.com.au