

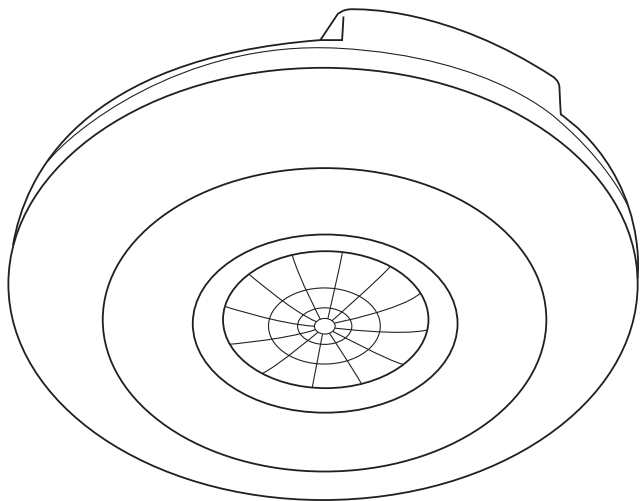

INFRARED SENSOR

I N S T R U C T I O N S



Model No: 55-308



CONTENTS

INTRODUCTION	3
IMPORTANT SAFETY INSTRUCTIONS	3
INSTALLING THE INFRARED SENSOR	4-5
SET UP AND OPERATION	6-9
TROUBLESHOOTING.....	10
TECHNICAL SPECIFICATIONS.....	11
WARRANTY INFORMATION	12

INTRODUCTION

The Housewatch indoor sensor is suitable for installation on ceilings in a range of indoor locations including offices, conference rooms, hotels, hallways, kitchens, pantries etc.

IMPORTANT SAFETY INSTRUCTIONS

Please follow these instructions carefully before attempting to install and operate this sensor.

- ⚠ Ensure power is isolated before performing any work on the sensor.
- ⚠ Ensure the voltage marked on the product is the same as the electrical power supply to be used.
- ⚠ DO NOT mount on a conductive surface.
- ⚠ Must be installed by a licensed electrician in accordance with AS/NZS 3000:2018.

INSTALLING THE INFRARED SENSOR

1) Isolate power

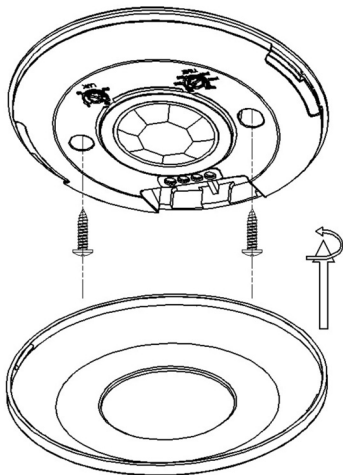

FIGURE 1

- 2) Remove top cover by turning anti-clockwise as per FIGURE 1.
- 3) Refer FIGURE 1. Use holes A on the sensor housing to mark the position of the fixing screws once the mounting position has been established.
- 4) If wall plugs are to be used drill a suitable hole to accommodate the wall plugs supplied. Taking care not to drill into any concealed electrical wiring or other services. Wall plugs must be pushed in until flush.
- 5) Drill a suitable hole to accommodate the electrical cable.
- 6) Pull through the electrical cable in preparation for connection to the sensor.

INSTALLING THE INFRARED SENSOR

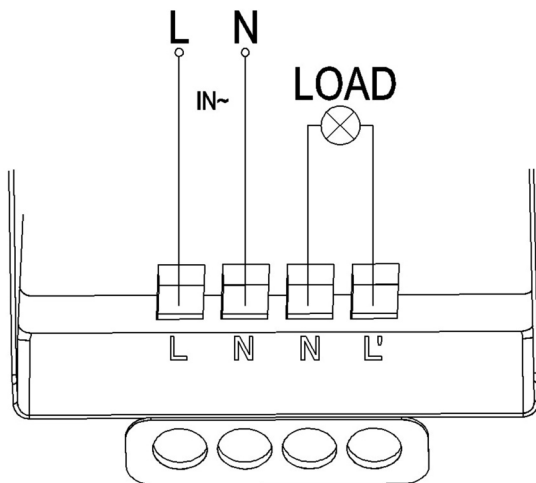

FIGURE 2

- 7) Connect the cable to the terminal block mounted on the back of the sensor housing as per FIGURE 2.
- 8) Fit the sensor housing to the ceiling using the screws provided.
- 9) Ensure that associated lighting loads are correctly installed according to the Australian wiring rules.
- 10) Reconnect power.

SET UP AND OPERATION

The indoor sensor is equipped with a highly sensitive PIR (Passive Infrared) motion detector. It utilises the infrared energy from the human body as the control signal source to switch the load on once it enters the detection field. The sensor automatically scans for movement between zones.

The indoor sensor will provide optimal performance and range when installed in a vertical position approximately 2.2 to 4m above the ground; as is shown in the diagrams in FIGURE 3 below. The horizontal coverage zone can reach up to 6m with an angle of 360°.

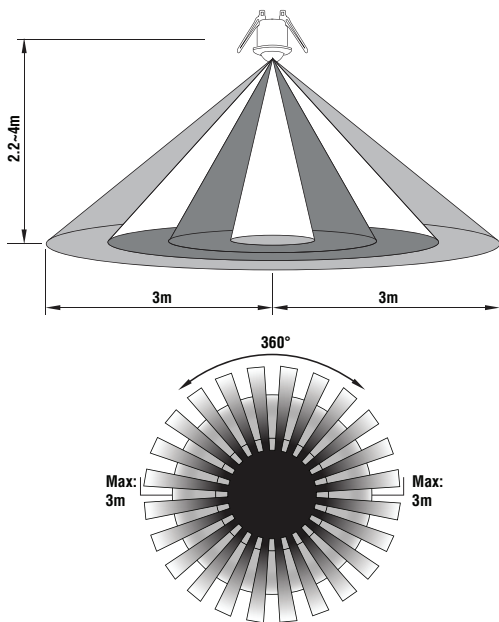

FIGURE 3

SET UP AND OPERATION

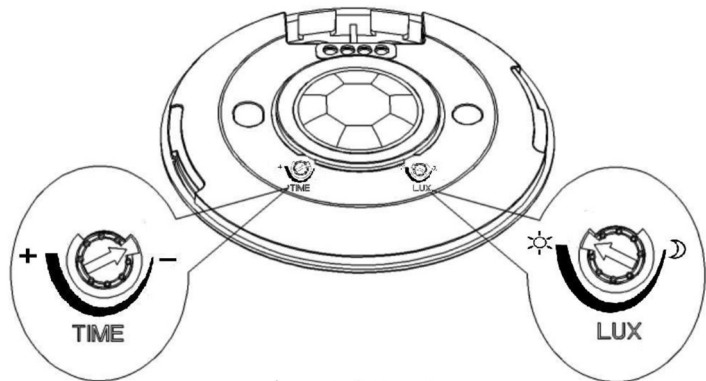

FIGURE 4

Time Duration:

The length of time the sensor will activate a load after detection can be adjusted from 10 seconds to 7 minutes ± 2 minutes. Rotating the time knob (marked with the clock) anti-clockwise will reduce the duration time.

Lux Level:

The sensor has a built in photoelectric cell that automatically detects daylight and darkness levels. Rotating the Lux control knob anti-clockwise (marked with the day/night image), will ensure that the sensor only works at night. By rotating the Lux control knob clockwise, the sensor will work in both daylight and at night depending on the application - the daylight setting is primarily used for testing the sensor after installation.

SET UP AND OPERATION

Walk Test

- 1) Rotate the Lux knob fully clockwise for daylight operation, set the time control to minimum (anti-clockwise).
- 2) Turn on the power at the isolating switch. The load should turn on for a short period of time (warm up 30 seconds).
- 3) Wait another 10 seconds for the circuit to stabilise.
- 4) Walk across the centre of the detection area until the load switches on. Your sensor is now ready for final adjusting.
- 5) Adjust the time control to the desired level.
- 6) Adjust the Lux control to revert to night time operation. If the load is required to switch on earlier, e.g. dusk; wait for the desired light level, and slowly turn the Lux knob clockwise while someone walks across the centre of the detection area.

Manual Override Feature

When the power is initially turned ON, the sensor operates in AUTO mode. In this mode, the sensor turns the load ON and OFF automatically.

The manual override function means that the sensor can be put permanently "ON". In this mode the PIR sensor is disabled.

SET UP AND OPERATION

Resetting the Sensor into “Manual Mode”

- 9) To bypass the “AUTO mode” and set the sensor into “MANUAL mode”, turn the wall switch “OFF” and “ON” twice within 2 seconds.

Wall switch action: OFF > ON > OFF > ON.

- 10) Wait for 3 seconds and the light will turn “ON” permanently and the sensor will be in the “MANUAL mode”.

Note: The maximum manual override time is 8 hours, after this time the sensor will automatically enter AUTO mode.

Setting the Sensor into “Auto Mode”

- 1) To change back to “AUTO mode”, turn the power “OFF” and wait for about 10 seconds, then turn it back “ON” again turning the switch “ON” once only.
- 2) Wall switch action: OFF, wait 10 seconds > ON.
- 3) The PIR sensor will enter into the “WARM-UP” mode and the load will stay “ON” for 10 seconds, then will turn “OFF”.
- 4) Now wait for about 10 seconds for the circuit to stabilise and the sensor will operate now in “AUTO mode”.

TROUBLESHOOTING

Problem	Possible Cause	Suggested Solution
Load does not turn off	<ol style="list-style-type: none">1) Auto off time is set too long2) Sensor is nuisance triggered3) Incorrect wiring	<ol style="list-style-type: none">1) Set auto off time to a shorter time and check if the load switches off2) Keep away from detection coverage to avoid activating sensor while doing the test3) Refer to wiring diagrams for correct connection
Load does not turn on	<ol style="list-style-type: none">1) Exceeding the detection range2) No power is supplied3) Incorrect wiring	<ol style="list-style-type: none">1) Walk in the effective detection range2) Switch on the power3) Refer to wiring diagrams for correct connection
Nuisance triggered	There are heat sources, highly reflective objects or any objects which may be swayed in the wind within the detection coverage	Avoid aiming the sensor towards heat sources, such as air conditionings, electric fans, heaters or any highly reflective surfaces. Make sure there are no swaying objects within the detection coverage.

TECHNICAL SPECIFICATIONS

Rated Voltage	220-240V ~ 50Hz
Rated Load	For Lighting LED Lamp: Max. 1000W Tungsten lamp: Max. 2000W Incandescent lamp: Max. 2000W
Detection Angle	360°
Detection Range	Up to 6m at 2.2 to 4m height
Auto Time Off Adjustment	From 10 seconds to 7 minutes \pm 2mins
Lux Adjustment	Adjustable from <3 Lux to 2000 Lux
Operating Temperature	-20°C to +40°C
Environmental Protection	IP20



Installation of electrical equipment must be carried out by a qualified electrician.
Contact a qualified electrician in the event of fault or break down.



MANUFACTURER'S WARRANTY

This Housewatch product is guaranteed for a period of 2 (Two) years from date of purchase, provided the product has been installed in accordance with this instruction manual and local electrical wiring regulations and codes of practice.

This guarantee shall become invalid if this product has been incorrectly installed, misused, tampered with or accidentally damaged.

If the goods are defective, we undertake to repair or replace the goods or any part of them that is defective; or provide again or rectify any services or part of them that are defective; or wholly or partly recompense you if they are defective.

This guarantee is in addition to other rights and remedies available to consumers, all of which are given by us to you if you are a consumer. Our Goods come with guarantees that cannot be excluded under the Australian Consumer Law. You are entitled to a replacement or refund for a major failure and for compensation for any other reasonably foreseeable loss or damage.

You are also entitled to have the goods repaired or replaced if the goods fail to be of acceptable quality and the failure does not amount to a major failure. If you wish to make a warranty claim, please return this product to the original place of purchase together with your purchase receipt, or contact us using the below details.

Proudly Distributed by



Repelec (Aust)

Locked Bag 45

Plumpton NSW 2761

Ph: 1300 555 586 Fax: 1300 666 066

Email: info@housewatch.com.au